

ProLine 2100

Custom designed for professional use



BENEFITS

- Superb accuracy
- Rotating indicator
- Big Piezo push buttons
- Exchangeable battery packs
- 100 hours battery life

The hi-tech standard
Extremely accurate



RAVAS

FUNCTIONS

- Automatic and manual zero correction
- Gross/net weighing
- Automatic tare over the full scale. Pre-set tare maximum first range (200 kg)
- Totalling with sequence number
- Error messages in display
- Automatic switch-off after 30 minutes of non-use
- Low battery indication 5 hours before battery is empty

STANDARD SPECIFICATIONS

- Weighing capacity 2,000 kg
- Graduation multirange:
0 - 200 kg: graduation 0,1 kg
200 - 400 kg: graduation 0,2 kg
400 - 2.000 kg: graduation 0,5 kg
- Max. tolerance 0,08% of the load lifted
- Display LCD, digit height 18 mm
- Keypad 4 Piezo function keys
- Protection class load cells IP67, indicator IP65
- Battery 12Vdc NiMH, exchangeable; battery charger included
- Battery 100 hours, low battery indication 5 hours before automatic switch-off
- Charger 230V NiMH charger
- Charging time approximately 6 hours
- Steering wheels rubber
- Loading wheels polyurethane, tandem
- Pump ergonomic lift
- Own weight 180 kg
- Colour Chassis red (RAL3000)
Fork shoe black (RAL9005)
Epoxy painted

DIMENSIONS IN MM

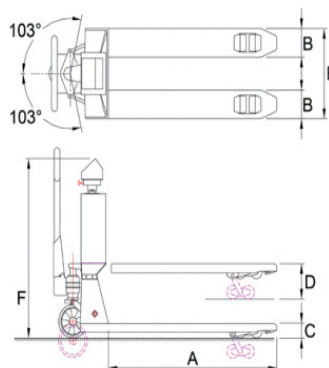

	Stand. chassis	Stainless chassis
A Fork length	1150	1150
B Fork width	160	160
C Minimum fork height	90	90
Minimum clearance	22	22
D Maximum fork height	205	205
E Width over forks	550	550
F Height to top indicator	1185	1185
Loading wheels		
- type: PU tandem	yes	no
- type: PU single	no	no
- type: Nylon tandem	no	yes
Steering wheels		
- type: rubber	yes	no
- type: Nylon	no	yes



Management System
ISO 9001:2015
ISO 14001:2015
ISO 45001:2018
www.tuv.com
ID 0000037200

OPTIONS*

- Legal for trade version, OIML III
- Premium quality stainless steel chassis
- Bluetooth or WLAN output
- Built-in thermal printer
- 0.1 kg graduation, maximum 1,000 kg capacity
- Stainless steel fork shoes
- 2 extra exchangeable batteries
- 690 mm width over the forks
- Atex version

RAVAS Europe B.V.

Veilingweg 17, 5301 KM Zaltbommel, The Netherlands

T: +31 418 515220 E: salesoffice@ravas.com

WWW.RAVAS.COM

