

CD351 1 SERIES SURFACE MOUNT

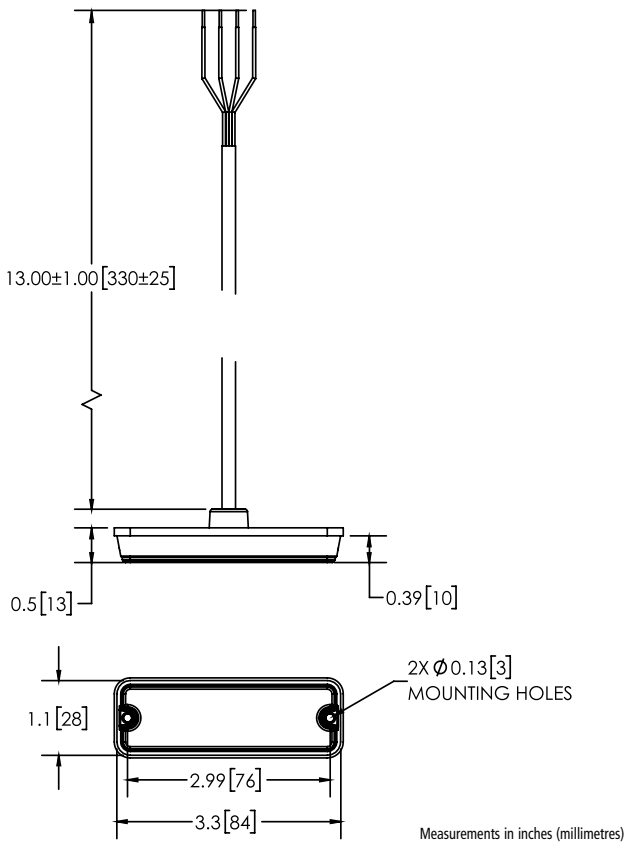

The CD3511 LED warning light is designed to offer maximum performance with a minimal footprint. This surface mount LED measures only 0.5" (13mm) deep, features 36 flash patterns and is available in blue, red or white. Its compact form allows for mounting in virtually any location on a vehicle body, while its twelve 1-watt LEDs provide high-intensity utility and warning lighting. With a low current draw, long maintenance-free service life and a 5-year warranty, the CD3511 Series is a small yet powerful LED for police, fire and ambulance vehicles.



VOLTS AMPS	12-24V 1.4A	
DIMS	1.1" H x 3.3" L x 0.51" D 28mm H x 84mm L x 13mm D	
FLASH PATTERNS	36	
CERTS	CLASS I (SAE J595), CE, R10, RCM, R65, IP67, RoHS	
DETAILS	<ul style="list-style-type: none"> • Twelve 1-watt high-intensity LEDs provide exceptional warning • Can be synchronised with additional CD3511s and Hide-A-LEDs • All electronics embedded in lighthouse • 13" (330mm) cable • UV-stabilized polycarbonate lens • 36 flash patterns 	
REPLACE	"_" with B = Blue, R = Red, W = White	
MODEL	TYPE	LED COLOURS
CD3511_	Single	A, B, R, W
CD3511__	Dual	AB, BW, RB

+44 (0)113 237 5340 | sales@eccogroup.com